

- 1 Mark the welding area with a marker and scrape the pipe surface carefully using a scraper.
- 2 After scraping, remove dirt and grease from the welding area of the pipe and the inside of the saddle, using an appropriate cleaning agent. Wait until the clean parts are completely dry.
- 3 Apply the saddle on to the pipe watching out not to dirty the previously cleaned surfaces (see fig.1).
- 4 Fasten the saddle on the pipe using the FLEXIBLE BELT: use a wrench to tighten the four screw nuts until the U-bolt A and the top part of saddle B come into tight contact (see fig.2).

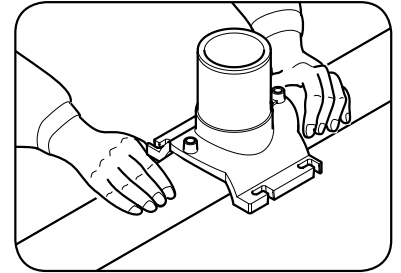

FIG.1

- 5 Connect the two cables of the electrofusion machine to the connectors of the branch saddle (see fig.3). Scan the bar code (see fig.6) with the bar code scanner or enter the welding parameters manually. **ALWAYS CHECK THE WELDING PARAMETERS.**

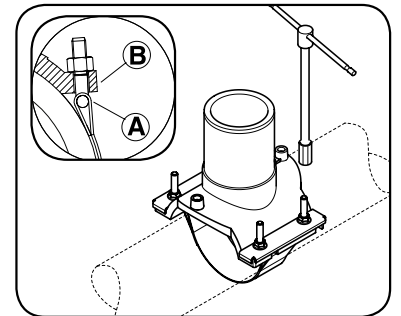

FIG.2

*For automatic welding units, always check the welding parameters on the barcode (see fig.6). For manual welding please use the time and voltage indicated on the barcode. If the welding unit does not perform welding time compensation according to ambient temperature, use the parameters in the label affixed on the bag (see fig.5). Keep at a safe distance during welding. The company is not responsible for any damage to persons or property if safety rules are not observed.*

- 6 After completing the welding process, verify that no material has leaked out of the joint between the pipe and the fitting. Wait for the cooling time as indicated on the fitting barcode before rough handling.

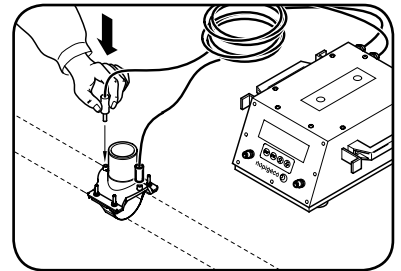

FIG.3

- 7 At the end of the cooling time it's possible to start the pressure test with the Pressure Sensor. In the following table (TABLE 1) you find the recommended waiting time in MINUTES before starting the test.

**For gas pipelines:** The Max Operating Pressure for this fitting is 145 PSI. The Max Test Pressure for this fitting is 217psi for 1 hour.

**DO NOT EXCEED MAX OPERATING OR MAX TEST PRESSURES.**

- 8 Proceed now with the perforation of the pipe through a specific cutter (see fig.4).

CHECK THAT THE DIAMETER OF THE CUTTER IS COMPATIBLE WITH THE INSIDE DIAMETER OF THE SPIGOT.  
AVOID ANY DAMAGE TO THE SPIGOT DURING THE PERFORATION.

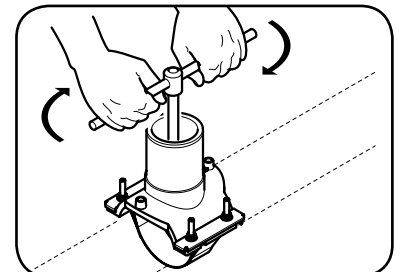

FIG.4

- 9 Connect the service line with the spigot of the outlet, following the installation instructions for that specific fitting.

- 10 The underclamp may be removed or left permanently.

TABLE 1

RECOMMENDED WAITING TIMES BEFORE PRESSURE TEST START			
FOR GAS APPLICATIONS			
Dn pipe	P ≤ 100 PSI	P ≤ 150 PSI	P ≤ 217 PSI
1"¼ ÷ 2"	cooling + 20'	cooling + 30'	cooling + 30'
2"½ ÷ 12"	cooling + 20'	cooling + 40'	cooling + 60'
FOR LIQUID APPLICATIONS			
Dn pipe	P ≤ 150 PSI	P ≤ 240 PSI	P ≤ 348 PSI
1"¼ ÷ 2"	cooling + 20'	cooling + 30'	cooling + 30'
2"½ ÷ 12"	cooling + 20'	cooling + 40'	cooling + 60'

FIG.5 MANUAL WELDING PARAMETERS

**EIOFIT** MADE IN ITALY 21/10/2011

**12**.....

00 V - 000s  
Cooling time 00 m ...  
Branch Saddle

< 5°C	>= 5°C < 15°C
... s	... s
>= 15°C < 30°C	> 30°C
... s	... s

0 000000 1 000000 U-00000

FIG.6 WELDING PARAMETERS

XXX000 - 00v - 000s - c.t. 00 min

Traceability code  
A 035662

950512154003400646919554  
3503315001706017060503398

<b>XXX00:</b>	FITTING CODE
<b>00v:</b>	TENSION
<b>000s:</b>	WELDING TIME
<b>c.t. 00 m:</b>	COOLING TIME

**ATTENTION! NEVER PERFORATE THE PIPE BEFORE COMPLETING WELDING.**

**RECOMMENDATIONS FOR THEIR DISPOSAL:** POLYETHYLENE USED FOR THIS ACCESSORY IS RECYCLABLE: DISPOSE THROUGH AUTHORISED CENTRES. DO NOT DISPERSE WRAPPING AND PACKAGING OF THE PRODUCT, RECYCLE THROUGH COLLECTION.